

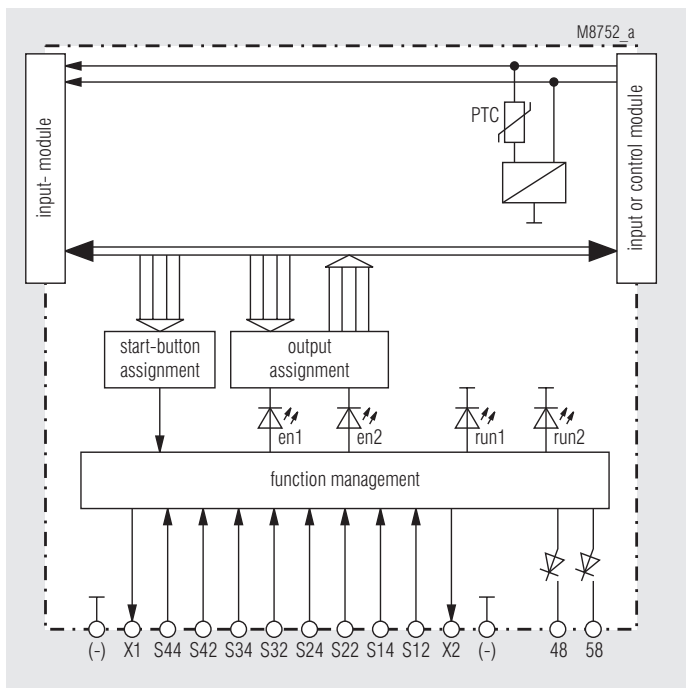

- According to
 - Performance Level (PL) e and category 4 to EN ISO 13849-1: 2008
 - SIL Claimed Level (SIL CL) 3 to IEC/EN 62061
 - Safety Integrity Level (SIL 3) to IEC/EN 61508
- Input module mit einer per Stufenschalter einstellbarer Combination of the following 3 functions:
 - Light curtains (LC) type 4 with manual or automatic start
 - E-stop 2-channel and manual or automatic start
 - Two-hand function type IIC according to DIN/EN 574
- The functions are selected via rotary switch
- 8 safety inputs
- 2 semiconductor outputs for status indication
- Broken wire and short circuit monitoring function with error indication
- LEDs for status indication
- Width: 22.5 mm

Block Diagram



Approvals and Markings



Applications

Realization of fail-safe control circuits for protection of people and machinery.

Note: This module is intended for applications in which mixed safety functions affect one common output.

Further input modules with other combinations of functions are provided (e.g. BG 5913.08/_0_ _ _ _ , BG 5913.08/_1_ _ _ _ , BG 5913.08/_3_ _ _ _ , BG 5914.08/_0_ _ _ _ , BH 5914.08/_0_ _ _ _ , BG 5914.08/_1_ _ _ _ , BG 5915/_1_ _ _ _ or BH 5915.08/_1_ _ _ _).

General Information SAFEMASTER M

The maximum configuration of the SAFEMASTER M multi-function safety system is as follows:

- the control unit BH 5911
- up to 3 input modules BG/BH 5913, or BG/BH 5914, BG/BH 5915
- up to 3 output modules BG 5912
- 1 diagnostic module BG 5551 for CANopen, or
- 1 diagnostic module BG 5552 for Profibus-DP

The BH 5911 controls the whole system.

The input/output modules can be used to expand the control unit in a modular way into a multi-functional safety system.

To transmit status messages of the individual modules to a monitoring or control unit, one of the following diagnostic modules may be connected:

- BG 5551 for CANopen
- BH 5552 for Profibus-DP

Indication

- Green LEDs: on, when all inputs are present and start button activated.
- White LEDs Run1/ Run 2 and outputs 48 and 58: indicate the current status of the module.

Circuit Diagram

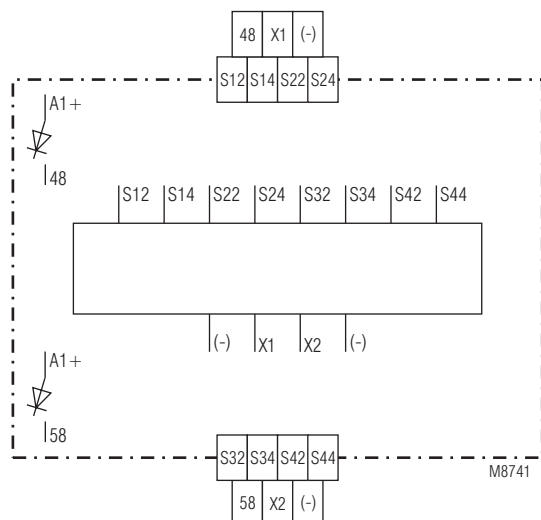

Setting of the Module

The module is assigned to the start inputs and the safety outputs via the DIP switches.

The combinations of individual functions are set via the rotary switches. To prevent accidentally adjustments, these elements are covered by a front plate and are redundant.

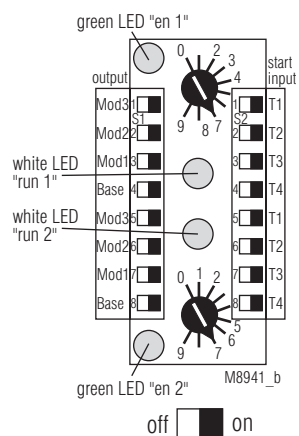
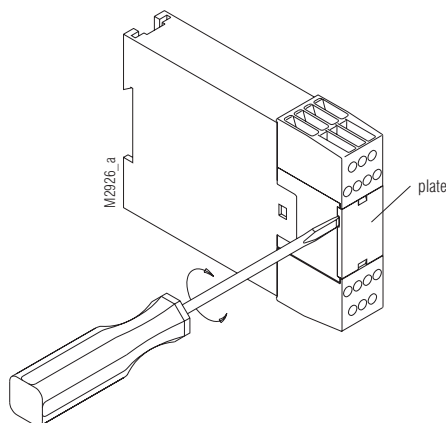

Note:

- Settings to the unit must be performed by skilled personnel while the unit is disconnected.
- Before the front cover is removed, antistatic precautions must be observed.

Setting of the Modules

Sw.	Function at Terminals				Start behavior of the LC / E-Stop
	S12-S14	S22-S24	S32-S34	S22-S24	
0	E-stop	E-stop	E-stop	LC	Autostart
1	E-stop	E-stop	E-stop	LC	Manual Start
2	E-stop	E-stop	LC	LC	Autostart
3	E-stop	E-stop	LC	LC	Manual Start
4	E-stop	LC	LC	LC	Autostart
5	E-stop	LC	LC	LC	Manual Start
6	E-stop	E-stop	Two-hand IIIC		Manual Start
7	LC	LC	Two-hand IIIC		Manual Start
8	E-stop	LC	Two-hand IIIC		Manual Start
9	E-stop	LC	Two-hand IIIC		Autostart

Functional Principle of combined inputs

Each function activates an enabling signal in the module software. The control unit is permitted to enable the assigned safety outputs only after all 3 (for two-hands control) or 4 enabling have been given.

With the exception of two-hand control, each function works independently. The assigned safety outputs are enabled if the precondition for enabling has been met for all functions.

Function of the Two-Hand Control

This function will only work when the other two functions have already permitted enabling. To provide for enabling, the two buttons must be pressed within 0.5 s. As soon as one of the other function reacts, the two buttons must turn inactive before the others can be enabled again. Only after that, the buttons can be activated once more from an inactivated state.

The unit must be connected as specified in the application examples. When the operating contacts are connected in parallel or in series, safe functioning of the unit is cancelled.

The two-hand buttons must be designed and arranged in such a way as to ensure that they cannot be disabled with easily, or pressed unintentionally.

The safety distance between the push buttons and the place of danger must be large enough to make sure that after releasing a button, the place of danger can only be reached after the dangerous movement has stopped.

The safety distance "S" is calculated according to the following formula:

$$S = V \times T + C, \text{ where}$$

- gripping velocity $V = 1\ 600\ \text{mm/s}$
- overtravel time $T\ (\text{s})$
- and safety factor $C = 250\ \text{mm}$.

When any access into the danger area, with operating keys pressed, is safely prevented, e.g. by a protective cover for the keys, the safety factor C may be set to the value 0. Generally, the minimum safety distance must be 100 mm. In this respect, also see DIN/EN 574.

The two-hand control must be released when another function module which affects the same outputs does not permit enabling. The system may comprise only one function module with two-hand control.

E-Stop or Light Curtain (LC) Function

In the Emergency stop or LC functions, both signals have to change from inactive state into active state within 250 ms. If the second signal reacts later, both changeover contacts must turn inactive before they can be enabled again.

With manual start, all safety inputs must be active before the start button can be pressed to trigger enabling. To start the system, do not keep the start button pressed for more than 3 seconds. A module may also be assigned several start buttons.

Note: Connect only self-testing light curtains of the type 4 acc. to EN 61496 to the module. Short-circuit monitoring of the inputs for the LC must be done in the LC.

Indication of System Errors:

These errors are indicated by flashing codes of the white LEDs Run 1 and/or Run 2. The green LEDs and all outputs turn inactive. The system will only restart after the supply voltage has been switched off and on again.

Error codes*

- 0) (both white LEDs are off):
Another input module indicates a system error.
- 1) To 4): not used
- 5) Incorrect setting of function:
 - The rotary switches for channel 1 and 2 has different or incorrect positions
 - The setting of the 4 upper Dip-switches (channel 1) are not identically to the 4 lower Dip-switches (channel 2)
- 6) LED Run 1 flashes: Undervoltage
LED Run 2 flashes: Overvoltage
- 7), 8) Not used
- 9) Connection error between the input modules
No terminating connector available.
 - Control or input module defective
- 10), 11), 12), 13) a. 14) Internal errors

* number of short flashing impulses, followed by a longer space

Function Error Indication

Function errors are indicated by the white LED Run 1 and by output 48; the white LED Run 2 remains on. Output 58 is ON as long as the error is pending; it flashes regularly, while waiting for the assigned start signal.

Error codes*

- 1) Normal interruption of function (e.g. Emergency stop)
- 2) Time error: (e.g. the second two-hand button is not pressed)
- 3) With gate monitoring: simulation input error (kept pressed for too long)
- 4) Error at start input
- 5) Input error (short-circuit, interruption)
- 6) Error in the control unit (input or output error detected in the control unit)

* number of short flashing impulses, followed by a longer space

Special with two-hand control:

When both two-hand buttons of the module are inactive while all other functions are active and enabled either by autostart or via the start button, output 48 and the white LED Run 1 are permanently OFF, and output 58 permanently ON.

Indication

	Permanently OFF	Pulsing	Permanent ON
Output 48	all relays inactive due to system error	one input function not available	Activation of the assigned safety outputs is permissible
LED run 1	Two-hand control not activated (LED run 2 ON) or all relays inactive due to system error	one input function not available (LED run 2 ON) or system error when LED Run 2 is OFF or flashing	Activation of the assigned safety outputs is permissible
Output 58	Activation of the assigned safety outputs is permissible or system error	Error exists no more, waiting for Start input	one input function not available
LED run 2	all relays inactive due to system error	all relays inactive due to system error	No system error

Function Diagrams

Note: The times specified in a pulse diagram also apply to the same function in other applications.

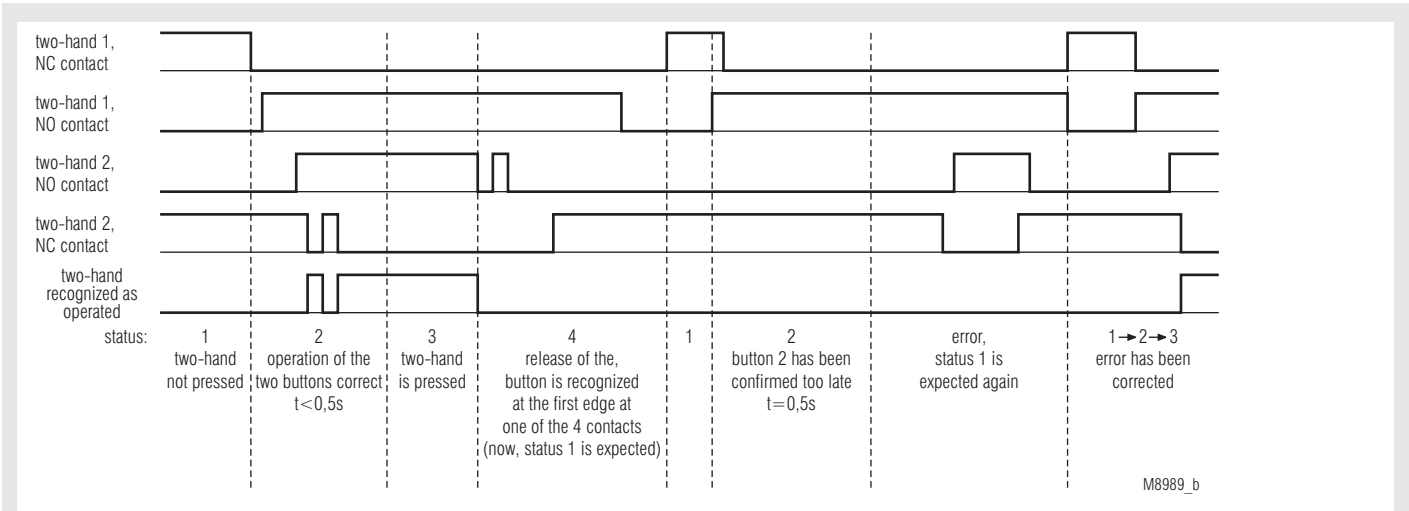

Two-hand control

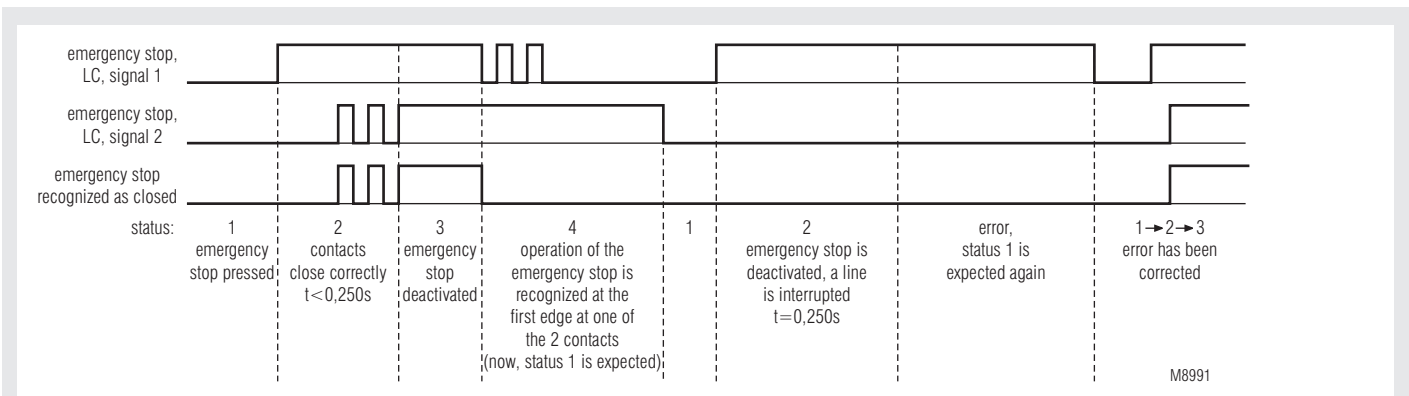

Emergency stop or light curtains

Function Diagrams

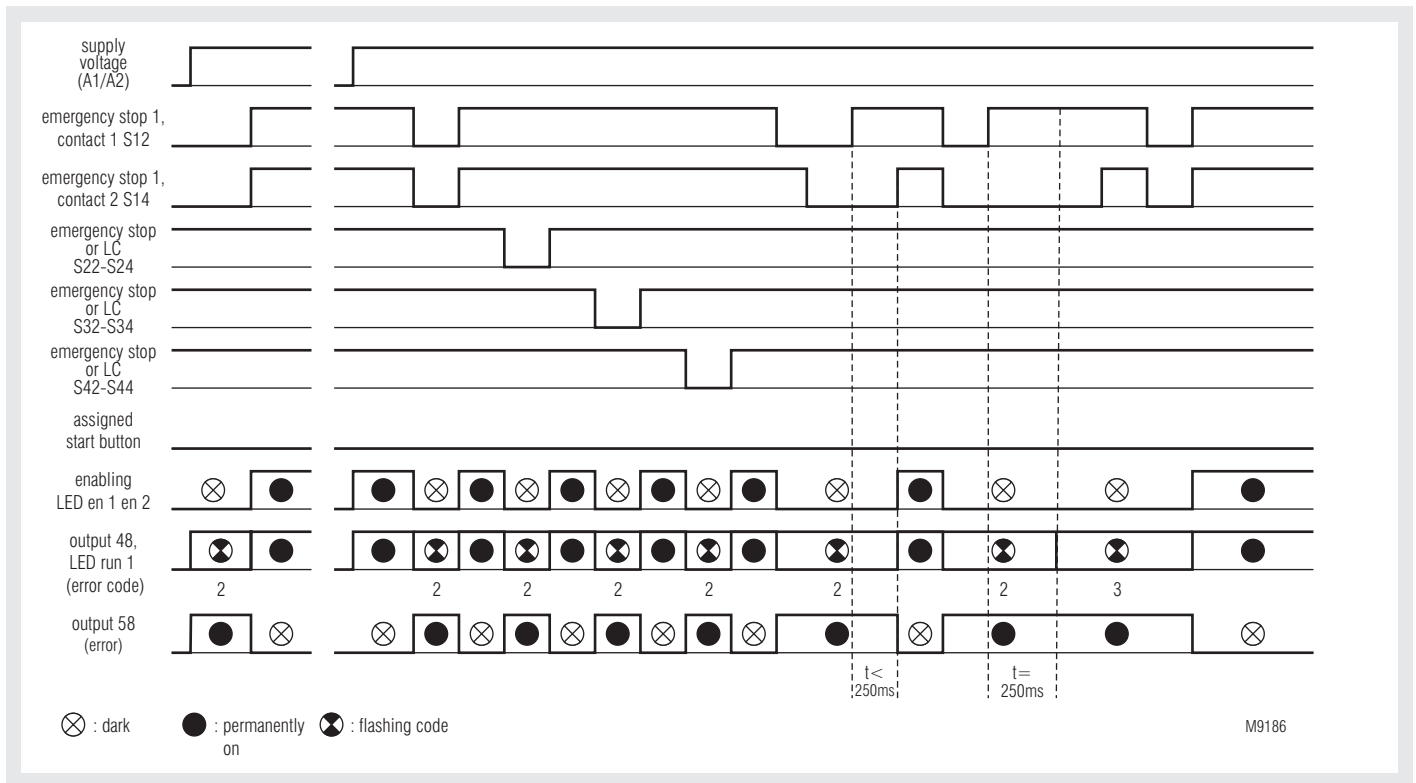

Emergency stop and light curtain, Autostart; functions 0, 2 or 4

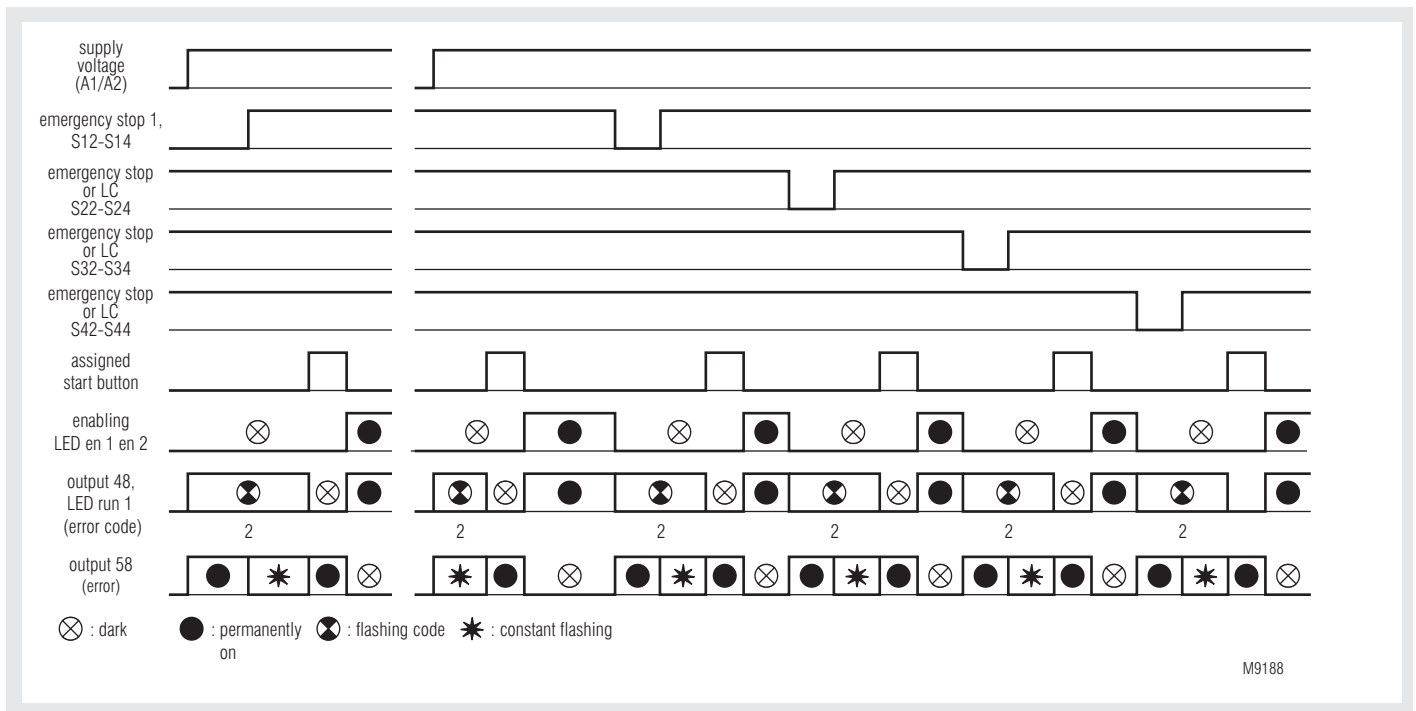

Emergency stop and manual start; functions 1, 3 or 5

Application Examples

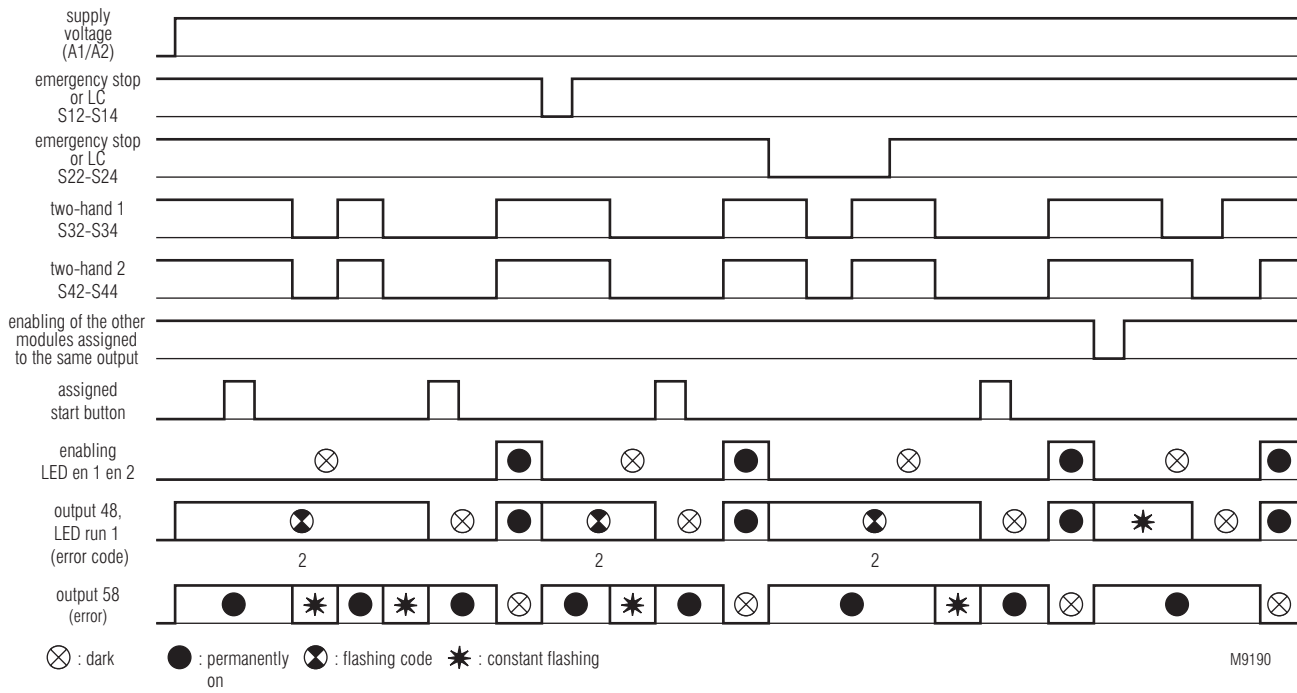

Emergency stop and / or light curtains, manual start, 1 two-hand control type IIC; functions: 6, 7 or 8

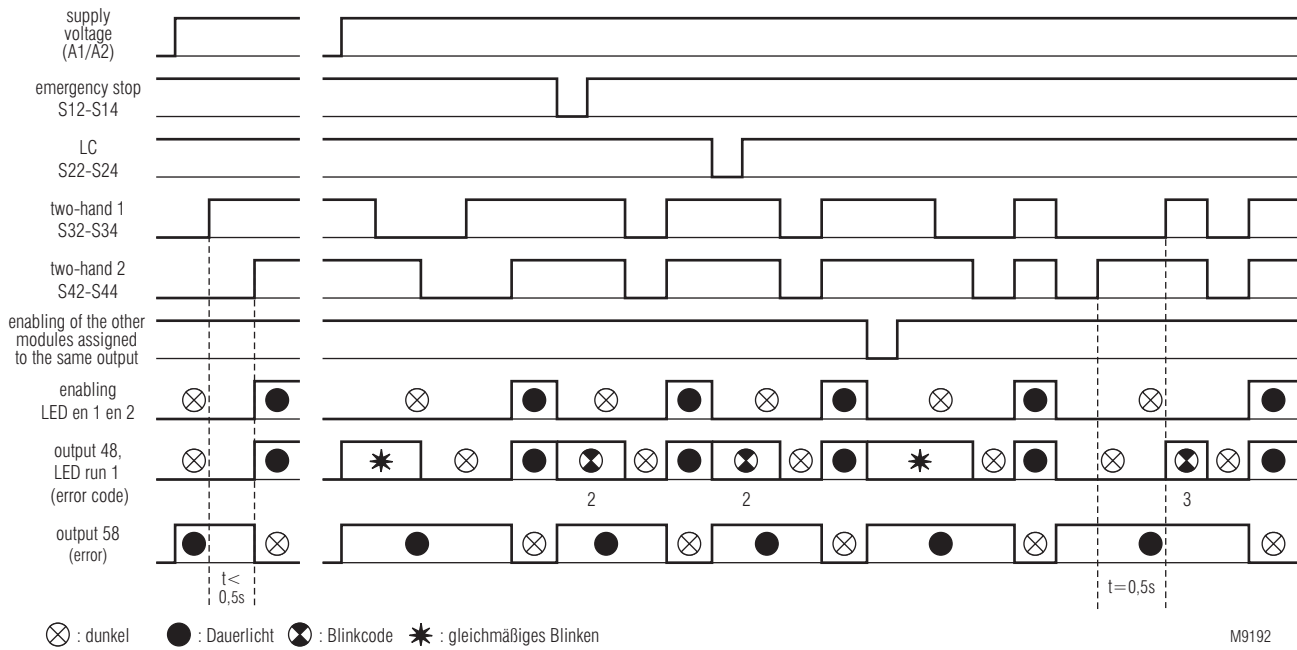

1 Emergency stop and 1 light curtain, Autostart, 1 two-hand control type IIC; function: 9

Application Examples

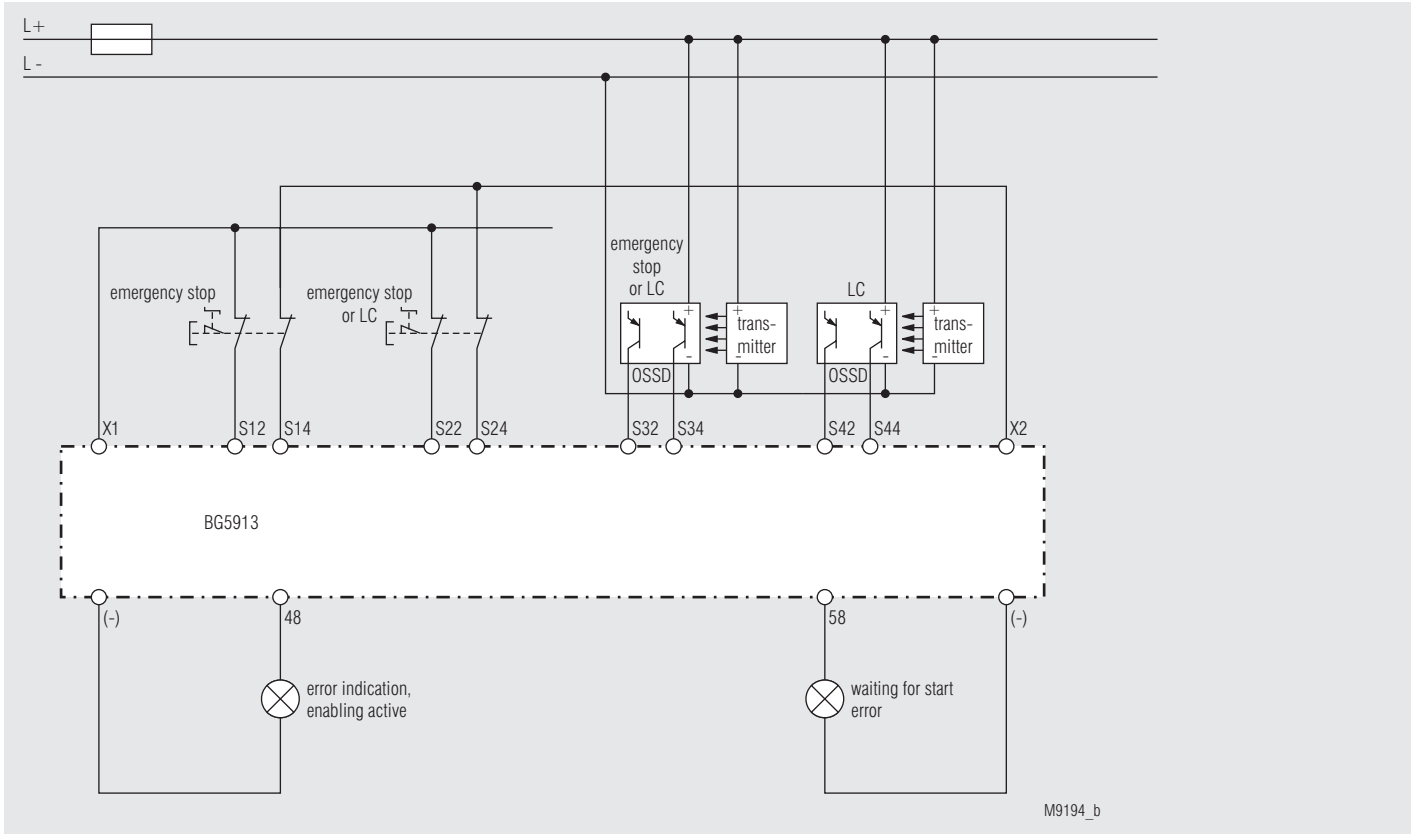

Emergency stop or light curtains; functions: 0, 1, 2, 3, 4 or 5

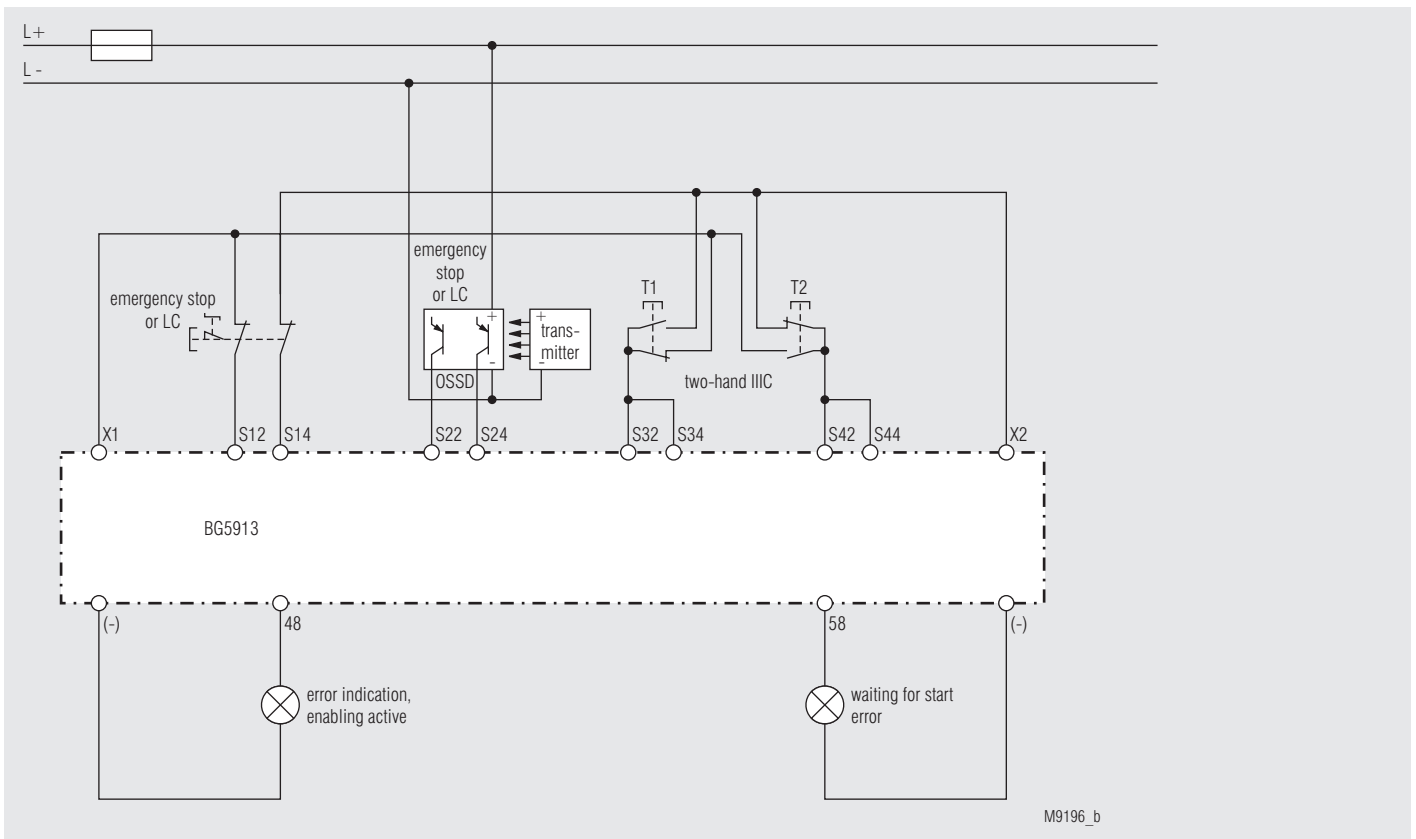

Emergency stop or light curtains, two-hand control type IIIC; functions 6, 7, 8 or 9

Technical Data**Voltage Supply**

Nominal voltage U_N : DC 24 V (coming from the basic module BH5911)

Voltage range:
with max. 5% residual ripple: 0.85 ... 1.15 U_N

Nominal consumption: max. 60mA
(no load on semiconductor outputs)

Short-circuit protection

of the modules: internally with PTC

Input**Control voltage**

via X1, X2, 48.58: DC 23 V at U_N

Control voltage

via S12, S14, S22, S24, S32, S34, S42, S44: 4.5 mA each at U_N

Minimum voltage

on S12, S14, S22, S24, S32, S34, S42, S44: DC 16 V

Semiconductor Outputs

Output at terminal 48 and 58: Transistor outputs, plus-connected
Output nominal voltage: DC 24 V, max. 100 mA constant current, max. 400 mA for 0.5 s
Internal short circuit, overtemperature, and overload protection

Reaction Times (time till reaction of the assigned output):**Typ. NO time with U_N :**

Input modules BG 5913	Manual start	Automatic start	
		First start	Restart
Emergency stop	max. 80 ms	max. 1 s	max. 115 ms
Light barriers	max. 80 ms	max. 1 s	max. 115 ms
Two-hand control	max. 85 ms		

Break time (reaction time): max. 33 ms

General Data

Operating mode: Continuous operation

Temperature range: $\pm 0 \dots + 50 \text{ }^\circ\text{C}$
At an operating temperature of $50 \text{ }^\circ\text{C}$ the modules must be mounted with a distance of 3 - 5 mm.

Clearance and creepage distances

rated impulse voltage / pollution degree: 4 kV / 2 (basis insulation) IEC 60 664-1

EMC: IEC/EN 61 326-3-1, IEC/EN 62 061

Radio interference suppression: Limit value class A EN 55011

Remark: This device is designed for industrial ambient conditions. When used in other environment, it is possible that wire bound or radiated interference occurs.

Degree of protection

Housing: IP 20 IEC/EN 60 529

Terminals: IP 20 IEC/EN 60 529

Housing: Thermoplastic with V0 behavior according to UL Subject 94

Vibration resistance: Amplitude 0.35 mm IEC/EN 60 068-2-6
Frequency 10...55 Hz,

Technical Data**Shock resistance**

Acceleration: 10 g
Pulse duration: 16 ms
Number of shocks: 1000 per axis on three axes
Climate resistance: 0 / 050/ 04 IEC/EN 60 068-1
Terminal designation: EN 50 005
Wire connection: 1 x 2.5 mm² stranded wire with sleeve, or 1 x 4 mm² massive or 2 x 1.5 mm² stranded wire with sleeve
DIN 46 228-1/-2/-3/-4

Wire fixing:

Box terminal with wire protection, removable terminal strips.

Mounting:

DIN rail IEC/EN 60 715

Weight:

165 g

Dimensions

Width x height x depth: 22.5 x 84 x 121 mm

Safety Related Data for E-STOP**Values according to EN ISO 13849-1:**

Category: 4
PL: e
MTTF_d: 812.8 a
DC_{avg}: 96.0 %
d_{op}: 365 d/a (days/year)
h_{op}: 24 h/d (hours/day)
t_{Zyklus}: 3600 s/Zyklus
≅ 1 /h (hour)

Values according to IEC EN 62061 / IEC EN 61508:

SIL CL: 3 IEC EN 62061
SIL 3 IEC EN 61508
HFT¹⁾: 1
DC_{avg}: 96.0 %
SFF: 99.2 %
PFH_D: 2.34E-10 h⁻¹

Safety Related Data for light curtains ,safety gates or two-hand**Values according to EN ISO 13849-1:**

Categorie: 4
PL: e
MTTF_d: 2697.1 a
DC_{avg}: 96.0 %
d_{op}: 220 d/a (days/year)
h_{op}: 12 h/d (hours/day)
t_{Zyklus}: 138 s/Zyklus

Values according to IEC/EN 62061 / IEC/EN 61508:

SIL CL: 3 IEC/EN 62061
SIL 3 IEC/EN 61508
HFT¹⁾: 1
DC_{avg}: 96.0 %
SFF: 99.2 %
PFH_D: 2.34E-10 h⁻¹

¹⁾ HFT = Hardware-Failure Tolerance



The values stated above are valid for the standard type.

Safety data for other variants are available on request.

The safety relevant data of the complete system has to be determined by the manufacturer of the system.

Standard Type

BG 5913.08/03MF0 DC 24 V
Article number: 0058703